

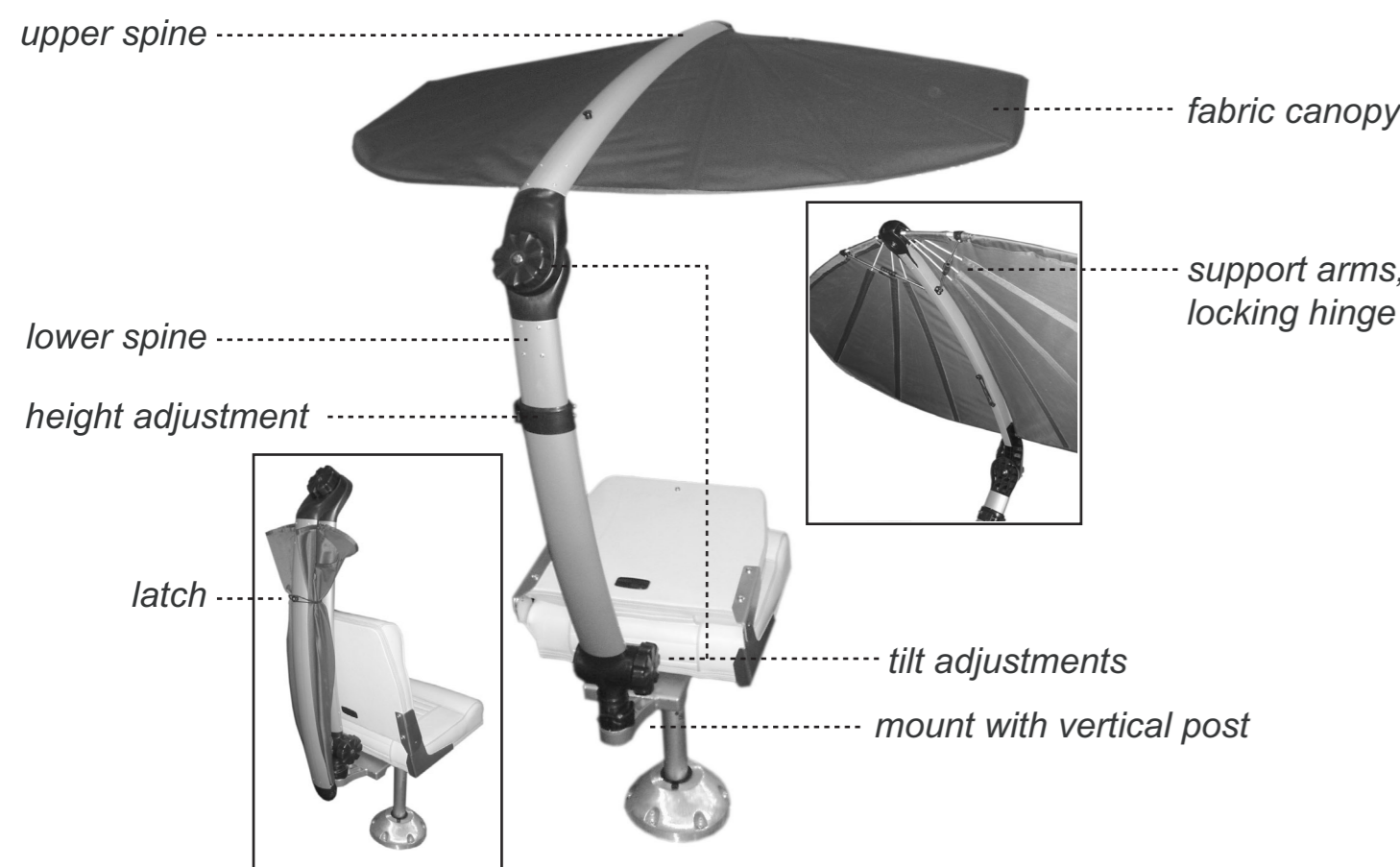

**Thank You for purchasing Mantis. We appreciate your business. Now get ready to experience a new level of comfort and convenience in weather protection!**

Your feedback is important to us. Please let us know what you think of our product, and send us your pictures using Mantis at: [feedback@pro-techt.com](mailto:feedback@pro-techt.com).

### Key product components



### Use and Care

#### Introduction

Mantis was designed and has been tested to effectively function in a wide array of environmental conditions. However, for safety reasons, and in order to provide a cost effective solution, Pro-Techt has defined certain user guidelines that serve as the basis by which Pro-Techt will warrant the Mantis product. Using Mantis in ways or conditions that exceed our recommended guidelines could cause premature damage to the product and will likely reduce the life of the product. **Usage outside of these guidelines could result in injury and will void your warranty.**

Following these usage guidelines, and exercising common sense, will ensure that your Mantis will provide you with years of comfort and protection while enabling you to have more enjoyable outdoor experiences.

#### Deployment and Adjustments

##### Cams (latch mechanisms)

After placing your Mantis on your mount, and adjusting for the desired position, always be sure to fully lock the cam to ensure a tight fit for this connection. Similarly, for Pro Models that have height adjustment, always be sure the cam is in the locked position once the desired height adjustment is determined.

Should your Mantis fit become too loose onto your mount or height adjustment, tighten (in small intervals) the lock nuts which are located on the left side of both latch mechanisms until the desired fit is achieved. Over tightening and loosening, or removing of the lock nuts could over time reduce its effectiveness and require replacement.

##### Knobs (tilt adjustments)

Always fully loosen the knobs when setting and adjusting the angles, and then fully tighten the knobs once the desired angles are achieved to ensure the Mantis will stay securely at the desired position. Should the fit become too loose on your tilt adjustment mechanisms, tighten (in small intervals) the lock nuts which secure the knobs until the desired fit is achieved. Over tightening and loosening, or removing of the lock nuts could over time reduce its effectiveness and require a replacement.

##### Using Mantis while Moving and in the Wind

Pro-Techt recognizes that wind can be a factor in many outdoor excursions. Mantis' aerodynamic canopy has been uniquely designed to minimize the impact of the wind. However, the Mantis has not been designed to withstand high travel speeds and/or wind. Therefore Pro-Techt has provided the following specific guidelines to ensure your Mantis will provide years trouble-free comfort and protection.

When moving more than a few MPH, always position Mantis in the overhead position. Pro-Techt recommends and warrants using Mantis only when combinations of travel and wind speed are 15 miles per hour or less. **Operating at travel and wind speeds greater than 15 mph with the Mantis in the open position is not recommended and will void your warranty.** When you want to travel at speeds in excess of 15 mph, Pro-Techt recommends that you close the fabric into the upper spine of Mantis, attach the fabric catch, loosen the pivot knob and swing your Mantis back so that the upper spine overlaps the lower spine and retighten the pivot knob. This takes just a few seconds and now you can travel at high speeds.

Mantis is plug-and-play, but you will first need to **install a mount**, which is sold separately. Use your Mantis in several places. Pro-Techt supplies several mounts for various applications. Take Mantis almost anywhere!

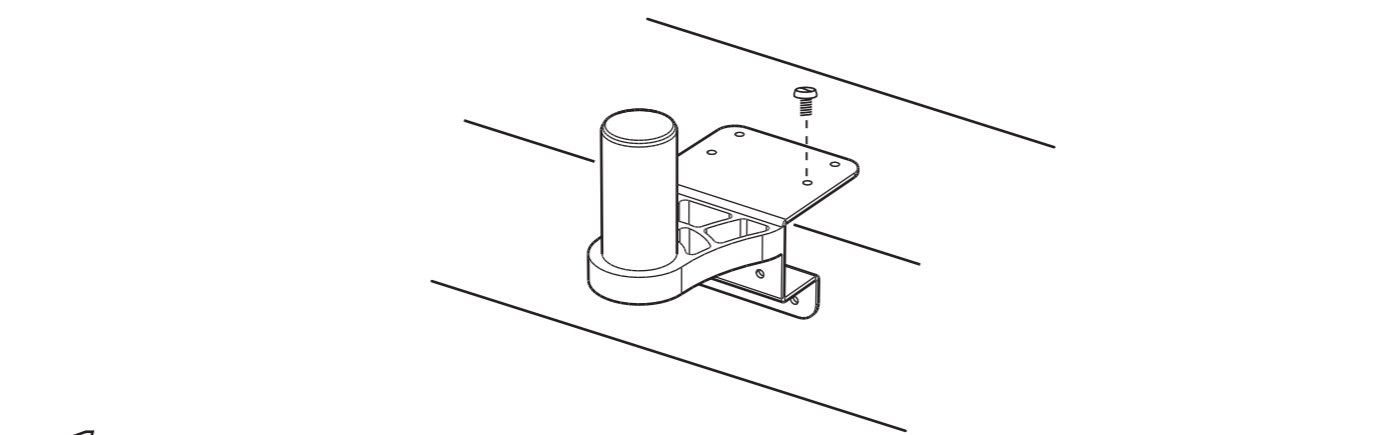
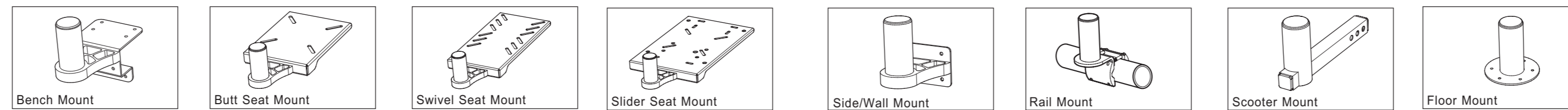

**1. INSTALL MOUNT**  
according to the directions provided with your particular mount(s).

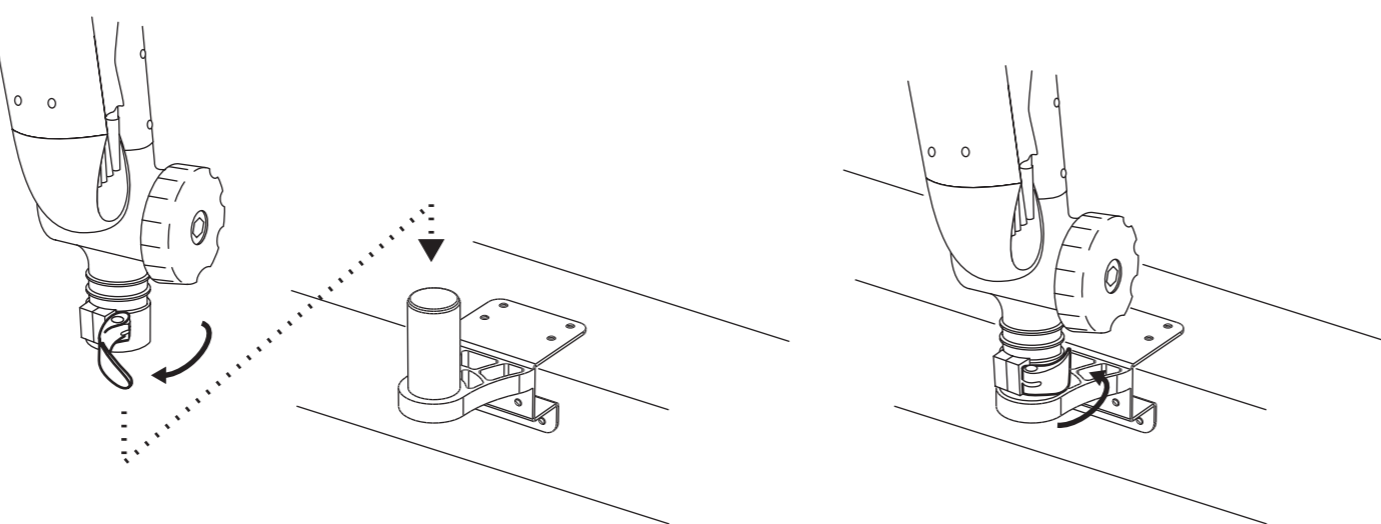

**2. PLACE ONTO MOUNT**  
With latch mechanism in the *open* position, lower the base of Mantis onto vertical Post and adjust to desired position. Then **fully close** the latch mechanism until it "locks" into place.

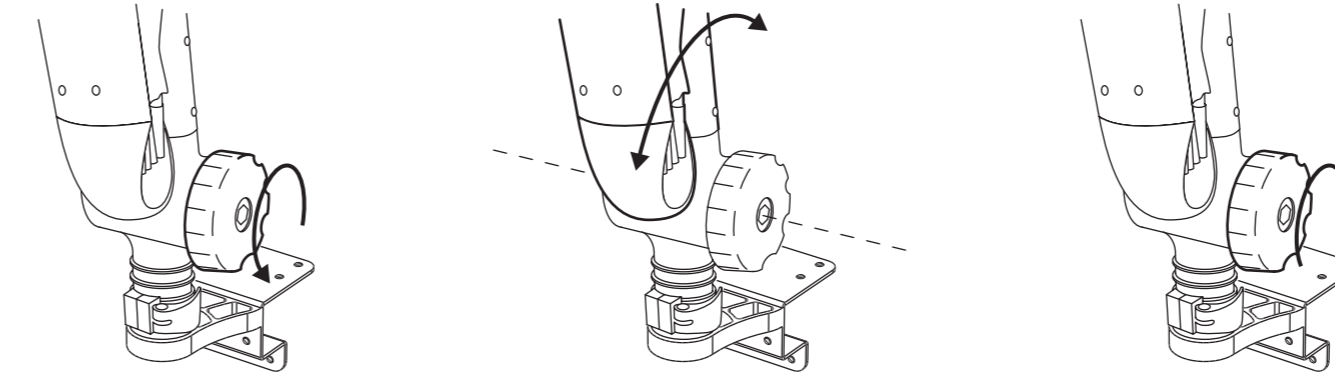

**3. ADJUST FRONT-TO-BACK POSITION**  
Loosen knob (counterclockwise) **all the way**, adjust angle, and **fully** tighten knob (clockwise) until secure.

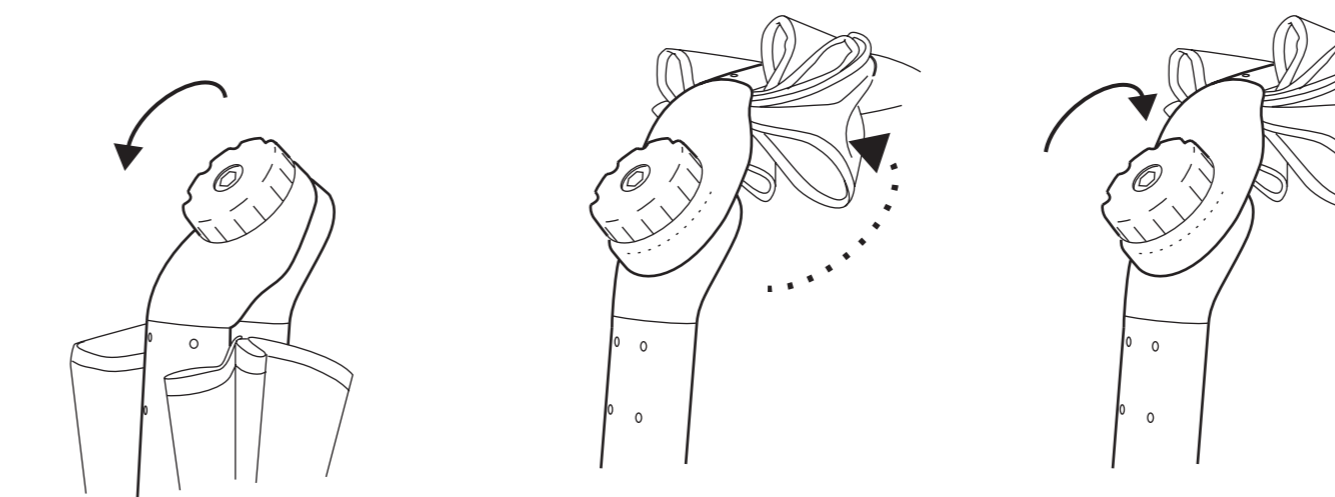

**4. SWING UPPER SPINE INTO PLACE** Loosen the knob (counterclockwise) **all the way**. Rotate upper spine into desired position. **Fully** tighten knob until secure.

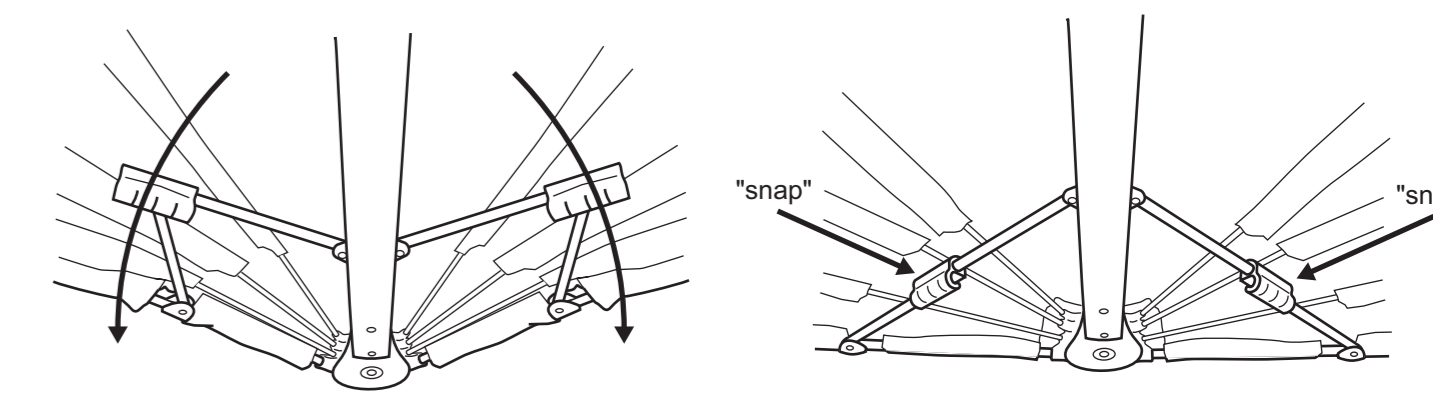

**5. DEPLOY CANOPY**  
Rotate the leading edge of one or both fabric shells into place, after un-fastening the elastic loops. Press locking hinge of support arm(s) into place, securing canopy in the open position. You're Done!

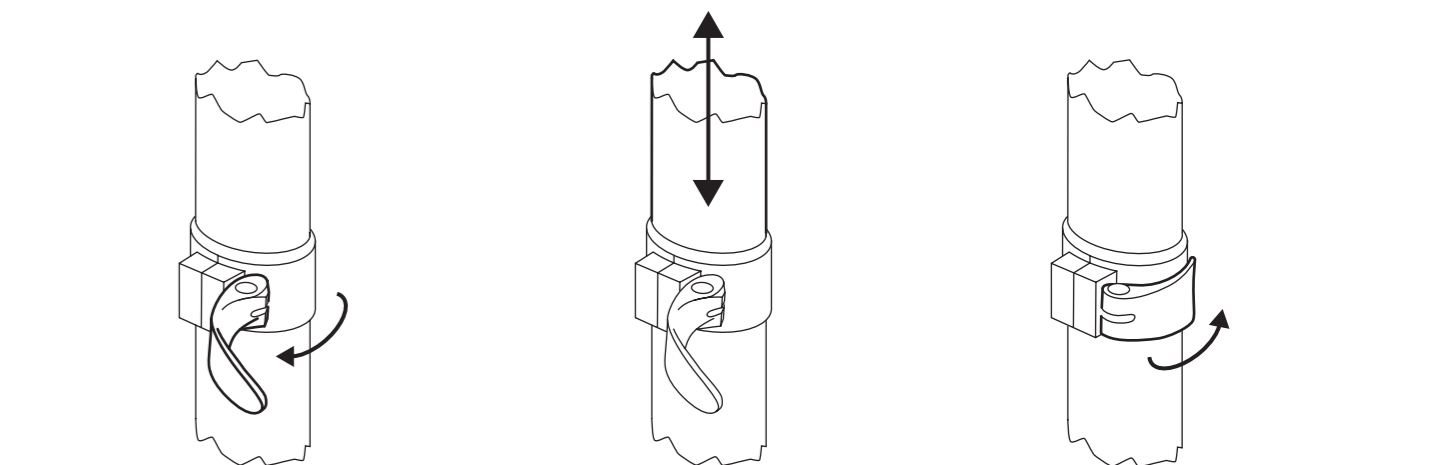

**6. ADJUST HEIGHT ("Pro" and "Pro+" models only)**  
With telescopic latch mechanism in the *open* position, raise the canopy vertically to the desired height, then **fully close** the latch mechanism until it "locks" into place.

Adjust pivot points as needed to optimize the location of Mantis for best protection. Follow these same steps, in reverse order, to store Mantis.



#### Cleaning and Care

With a minimal of care, Mantis will remain attractive and functional for years. **Pro-Techt recommends that you always rinse off your Mantis with fresh water after exposure to salt water and let dry before storing.**

##### Fabric Removal

The fabric top on your Mantis is easily removable for cleaning. The top is secured by velcro along the upper spine. To remove, start by holding the fabric near the base of the upper spine and gently separate the fabric from the spine. Once the fabric is separated along the entire spine, separate the velcro connected fabric at the inner most portions of the Mantis arms. Now the top can be easily removed by sliding it off of the arms and battens.

##### Cleaning

One of the best ways to keep fabrics looking good and to delay the need for deep or vigorous cleanings is to hose fabrics off on a monthly basis with clear water. This practice will help prevent dirt from becoming deeply embedded in the fabric and eliminate the need for more frequent vigorous cleanings. In most environments, a thorough cleaning will be needed every two to three years. Once separated, follow these instructions for cleaning both the polyester and Sunbrella Fabrics:

- Place your Mantis fabric in a washing machine and follow these steps:
  - Use only natural soaps (like antibacterial dish washing liquid), never detergent.
  - Wash and rinse in cold water.
  - Air dry. Never put the fabric in your dryer.
- For Sunbrella fabrics, if stubborn stains persist, you can use a diluted chlorine bleach/soap mixture for spot cleaning (see <http://www.sunbrella.com> for specific recommendations on how to get out difficult stains and other relevant information).

##### Retreating the Fabric

As part of the finishing process, the fabrics are treated with a finish that enhances water repellency. This finish is designed to last for several years, but must be replenished after a thorough cleaning. Pro-Techt recommends 303 High Tech Fabric Guard® as the preferred retreatment product for our fabrics. Fabrics should be retreated after thorough cleaning or after five years of use. 303 should be applied to fabrics after each thorough cleaning, which typically removes the original fluorocarbon finish and reduces the fabric's water repellency. After cleaning the fabric, allow it to air dry completely and then apply 303 in a thin, even coat. After allowing the first coat of 303 to air dry, apply a second thin, even coating of 303. Two light coatings are more effective in restoring fabric water resistance than a single heavy coating. A 15-ounce bottle provides coverage of up to 50 square feet of lightweight fabric. Always apply 303 to clean fabric.

##### Mantis Spines and Plastic

The anodized aluminum spines and plastic should be wiped clean as needed with a non-abrasive household cleaner.

##### Storage

Mantis fabrics and components are rot, mildew and rust resistant, however we recommend that you do not store Mantis wet for extended periods of time. If wet, simply wipe off and leave the fabric in the open position until dry before storing.

#### Pro-Techt RETURN POLICY, LIMITED WARRANTY & F.O.B. Point YOUR SATISFACTION IS GUARANTEED

Congratulations and thank you for purchasing the Mantis top by Pro-Techt. Your complete satisfaction with our products and company is important to us. Pro-Techt makes every effort to see to it that our products are of the highest quality and are designed to withstand the challenges associated with use in an outdoor environment.

Since we cannot guarantee that all products are applicable to all situations, and that the data we provide from many sources is reliable and accurate for all situations, our lawyers want you to know that all statements, technical data, and Pro-Techt recommendations contained herein are based upon tests we believe to be reliable. However, the accuracy or completeness thereof is not guaranteed. The proper and correct application of products and data is the responsibility of the user. Dimensions, operating characteristics, specifications, materials, finishes and component parts are subject to change without notice.

The following is made in lieu of all warranties, expressed or implied: Pro-Techt's only obligation shall be to replace such quantity of the product proved to be defective. Pro-Techt shall not be liable for any injury, loss, or damage, direct or consequential, arising out of the use of or the inability to use the product. Before using, users shall determine the suitability of the product for their intended use, and users assume all risk and liability whatsoever in connection therewith.

No statement or Pro-Techt recommendations not contained herein shall have any force or effect unless embodied in a written agreement signed by authorized officers of Pro-Techt, LLC

**RETURN POLICY:** Pro-Techt wants its customers to be completely satisfied. If you are dissatisfied in any way with any Pro-Techt products you purchase, you may return these products in their original undamaged condition with original packaging and proof of purchase within 30 days from the date of purchase. Upon receipt, Pro-Techt will refund your purchase price. Pro-Techt does not charge a restocking fee, but we do ask that any unit returned should be shipped prepaid to our receiving location. As Pro-Techt is not responsible for damages incurred during any incoming shipment, it is recommended that the customer insure their shipment through their carrier. Please call our Customer Service Department at 404-929-9980 or email us at [customer-care@pro-techt.com](mailto:customer-care@pro-techt.com) for a Return Material Authorization number (RMA#) and proper shipping instructions and address. Please include a copy of your original packing slip, invoice, or other proof of date of purchase.

**LIMITED WARRANTY:** Pro-Techt expressly warrants that Pro-Techt products used by the original purchaser for personal use will be free of defects in material (parts) and workmanship (labor) to the original owner for the period of time from the date of purchase as defined below:

- Mantis Aluminum Spines: Lifetime
- All Plastic Parts: One year
- Screws, rivets, and other metal components: One year
- Polyester fabric: One year
- Sunbrella Fabric on Plus Models: Five years
- Mounts: One year

All products and parts used or placed into service for commercial use are limited to a 180-day warranty period from the date of purchase.

#### Pro-Techt RETURN POLICY, LIMITED WARRANTY & F.O.B. Point YOUR SATISFACTION IS GUARANTEED- cont.

Within the warranty period defined above for specific components, a unit will be tested, repaired or replaced at Pro-Techt's sole election, free of charge. Please call our Customer Service Department at 404-929-9980 or email us at [customer-care@pro-techt.com](mailto:customer-care@pro-techt.com) for a Warranty Return Authorization number (WRA#) and proper shipping instructions and address. Please include a copy of your original packing slip, invoice, or other proof of date of purchase. Any unit under warranty should be shipped prepaid and insured to the factory. As Pro-Techt will not be responsible for damages incurred during any incoming shipment, it is recommended that the customer insure their shipment through their carrier. Pro-Techt, LLC will pay shipping charges associated with the return of Goods back to the customer. Warranty replacements will take approximately two weeks, assuming Pro-Techt has the product in stock. If the product/part is out of stock, Pro-Techt will make all reasonable efforts to repair or replace your product as soon as possible thereafter. If your unit is out of warranty Pro-Techt will quote repair charges necessary to bring your unit up to factory standards.

**WARRANTY EXCLUSIONS:** THE FOREGOING EXPRESS WARRANTY IS MADE IN LIEU OF ALL OTHER PRODUCT WARRANTIES, EXPRESSED AND IMPLIED, INCLUDING MERCHANTABILITY AND FITNESS FOR A PARTICULAR PURPOSE WHICH ARE SPECIFICALLY DISCLAIMED. THE REMEDIES STATED HEREIN ARE EXCLUSIVE REMEDIES AND PRO-TECHT, LLC SHALL NOT BE RESPONSIBLE OR LIABLE FOR ANY INDIRECT, CONSEQUENTIAL OR INCIDENTAL DAMAGES OR FURTHER LOSS OF ANY KIND WHATSOEVER INCLUDING THE INABILITY TO USE THE PRODUCTS, INCLUDING BUT NOT LIMITED TO, CLAIMS BASED UPON LOSS OF USE, LOSS OF TIME, INCONVENIENCE, COMMERCIAL LOSS, LOST PROFITS, REVENUE OR SAVINGS, LOST GOODWILL, ENVIRONMENTAL DAMAGE, INCREASED EXPENSES OF OPERATION, COST OF REPLACEMENT GOODS, OR CLAIMS OF THE CUSTOMER OR CUSTOMER'S CUSTOMERS, WHETHER OR NOT BASED ON ACTIONS OF CONTRACT, NEGLIGENCE OR OTHER TORTUOUS ACTION, ARISING OUT OF OR IN CONNECTION WITH THE USE OR PERFORMANCE OF THE PRODUCTS OR INFORMATION AVAILABLE HEREIN. THE INFORMATION AND GRAPHICS PUBLISHED HEREIN COULD INCLUDE TECHNICAL INACCURACIES OR TYPOGRAPHICAL ERRORS. CHANGES ARE PERIODICALLY MADE TO THE INFORMATION CONTAINED HEREIN. CHANGES AND/OR IMPROVEMENTS MAY BE MADE TO THE PRODUCT(S) AND/OR PROGRAM(S) DESCRIBED HEREIN AT ANY TIME BY PRO-TECHT, LLC OR THE MANUFACTURER OF SUCH PRODUCT.

This express warranty does not apply to defects or damage due to accidents, neglect, misuse, alterations, modifications, operator error, normal wear and tear, repair by others, Acts of God, or failure to properly maintain, clean or repair products. This exclusion includes: scratches, dents, rips or other defects or damages associated with normal wear and tear, misuse, or negligence or associated with operating our products outside of our usage and care guidelines including using Mantis in the open position when traveling at wind/travel speeds which exceed 15 mph.

**LIMIT OF LIABILITY:** In no event will Pro-Techt or any seller be responsible or liable for any injury, loss or damage, direct or consequential, arising out of the use of or the inability to use the product. Before using, users shall determine the suitability of the product for their intended use, and users assume all risk and liability whatsoever in connection therewith.

**F.O.B. Point**  
Unless embodied in a written agreement signed by authorized officers of Pro-Techt, LLC, the F.O.B. point for all products purchased from Pro-Techt will be the F.O.B. our offices in Atlanta, GA..